



**ANSI/TIA-568-C.3-2008**  
**Approved: June 18, 2008**

# **TIA STANDARD**

---

## **Optical Fiber Cabling Components Standard**

---

**TIA-568-C.3**  
(Revision of TIA-568-B.3)

**June 2008**

---

**TELECOMMUNICATIONS INDUSTRY ASSOCIATION**



## NOTICE

TIA Engineering Standards and Publications are designed to serve the public interest through eliminating misunderstandings between manufacturers and purchasers, facilitating interchangeability and improvement of products, and assisting the purchaser in selecting and obtaining with minimum delay the proper product for their particular need. The existence of such Standards and Publications shall not in any respect preclude any member or non-member of TIA from manufacturing or selling products not conforming to such Standards and Publications. Neither shall the existence of such Standards and Publications preclude their voluntary use by Non-TIA members, either domestically or internationally.

Standards and Publications are adopted by TIA in accordance with the American National Standards Institute (ANSI) patent policy. By such action, TIA does not assume any liability to any patent owner, nor does it assume any obligation whatever to parties adopting the Standard or Publication.

This Standard does not purport to address all safety problems associated with its use or all applicable regulatory requirements. It is the responsibility of the user of this Standard to establish appropriate safety and health practices and to determine the applicability of regulatory limitations before its use.

(From Project No. 3-3894, formulated under the cognizance of the TIA TR-42 User Premises Telecommunications Cabling Requirements, TR-42.8 Subcommittee on Telecommunications Optical Fiber Cabling Systems (568B.3).

Published by

©TELECOMMUNICATIONS INDUSTRY ASSOCIATION  
Standards and Technology Department  
2500 Wilson Boulevard  
Arlington, VA 22201 U.S.A.

**PRICE: Please refer to current Catalog of  
TIA TELECOMMUNICATIONS INDUSTRY ASSOCIATION STANDARDS  
AND ENGINEERING PUBLICATIONS  
or call IHS, USA and Canada  
(1-877-413-5187) International (303-397-2896)  
or search online at <http://www.tiaonline.org/standards/catalog/>**

All rights reserved  
Printed in U.S.A.

# NOTICE OF COPYRIGHT

**This document is copyrighted by the TIA.**

**Reproduction of these documents either in hard copy or soft copy (including posting on the web) is prohibited without copyright permission.** For copyright permission to reproduce portions of this document, please contact TIA Standards Department or go to the TIA website ([www.tiaonline.org](http://www.tiaonline.org)) for details on how to request permission. Details are located at:

<http://www.tiaonline.org/standards/catalog/info.cfm#copyright>

OR

Telecommunications Industry Association  
Standards & Technology Department  
2500 Wilson Boulevard, Suite 300  
Arlington, VA 22201 USA  
+1(703)907-7700

Organizations may obtain permission to reproduce a limited number of copies by entering into a license agreement. For information, contact:

IHS  
15 Inverness Way East  
Englewood, CO 80112-5704 or call  
U.S.A. and Canada (1-800-525-7052)  
International (303-790-0600)



## **NOTICE OF DISCLAIMER AND LIMITATION OF LIABILITY**

The document to which this Notice is affixed (the “Document”) has been prepared by one or more Engineering Committees or Formulating Groups of the Telecommunications Industry Association (“TIA”). TIA is not the author of the Document contents, but publishes and claims copyright to the Document pursuant to licenses and permission granted by the authors of the contents.

TIA Engineering Committees and Formulating Groups are expected to conduct their affairs in accordance with the TIA Engineering Manual (“Manual”), the current and predecessor versions of which are available at <http://www.tiaonline.org/standards/procedures/manuals/> TIA’s function is to administer the process, but not the content, of document preparation in accordance with the Manual and, when appropriate, the policies and procedures of the American National Standards Institute (“ANSI”). TIA does not evaluate, test, verify or investigate the information, accuracy, soundness, or credibility of the contents of the Document. In publishing the Document, TIA disclaims any undertaking to perform any duty owed to or for anyone.

If the Document is identified or marked as a project number (PN) document, or as a standards proposal (SP) document, persons or parties reading or in any way interested in the Document are cautioned that: (a) the Document is a proposal; (b) there is no assurance that the Document will be approved by any Committee of TIA or any other body in its present or any other form; (c) the Document may be amended, modified or changed in the standards development or any editing process.

The use or practice of contents of this Document may involve the use of intellectual property rights (“IPR”), including pending or issued patents, or copyrights, owned by one or more parties. TIA makes no search or investigation for IPR. When IPR consisting of patents and published pending patent applications are claimed and called to TIA’s attention, a statement from the holder thereof is requested, all in accordance with the Manual. TIA takes no position with reference to, and disclaims any obligation to investigate or inquire into, the scope or validity of any claims of IPR. TIA will neither be a party to discussions of any licensing terms or conditions, which are instead left to the parties involved, nor will TIA opine or judge whether proposed licensing terms or conditions are reasonable or non-discriminatory. TIA does not warrant or represent that procedures or practices suggested or provided in the Manual have been complied with as respects the Document or its contents.

If the Document contains one or more Normative References to a document published by another organization (“other SSO”) engaged in the formulation, development or publication of standards (whether designated as a standard, specification, recommendation or otherwise), whether such reference consists of mandatory, alternate or optional elements (as defined in the TIA Engineering Manual, 4<sup>th</sup> edition) then (i) TIA disclaims any duty or obligation to search or investigate the records of any other SSO for IPR or letters of assurance relating to any such Normative Reference; (ii) TIA’s policy of encouragement of voluntary disclosure (see Engineering Manual Section 6.5.1) of Essential Patent(s) and published pending patent applications shall apply; and (iii) Information as to claims of IPR in the records or publications of the other SSO shall not constitute identification to TIA of a claim of Essential Patent(s) or published pending patent applications.

TIA does not enforce or monitor compliance with the contents of the Document. TIA does not certify, inspect, test or otherwise investigate products, designs or services or any claims of compliance with the contents of the Document.

ALL WARRANTIES, EXPRESS OR IMPLIED, ARE DISCLAIMED, INCLUDING WITHOUT LIMITATION, ANY AND ALL WARRANTIES CONCERNING THE ACCURACY OF THE CONTENTS, ITS FITNESS OR APPROPRIATENESS FOR A PARTICULAR PURPOSE OR USE, ITS MERCHANTABILITY AND ITS NONINFRINGEMENT OF ANY THIRD PARTY’S INTELLECTUAL PROPERTY RIGHTS. TIA EXPRESSLY DISCLAIMS ANY AND ALL RESPONSIBILITIES FOR THE ACCURACY OF THE CONTENTS AND MAKES NO REPRESENTATIONS OR WARRANTIES REGARDING THE CONTENT’S COMPLIANCE WITH ANY APPLICABLE STATUTE, RULE OR REGULATION, OR THE SAFETY OR HEALTH EFFECTS OF THE CONTENTS OR ANY PRODUCT OR SERVICE REFERRED TO IN THE DOCUMENT OR PRODUCED OR RENDERED TO COMPLY WITH THE CONTENTS.

TIA SHALL NOT BE LIABLE FOR ANY AND ALL DAMAGES, DIRECT OR INDIRECT, ARISING FROM OR RELATING TO ANY USE OF THE CONTENTS CONTAINED HEREIN, INCLUDING WITHOUT LIMITATION ANY AND ALL INDIRECT, SPECIAL, INCIDENTAL OR CONSEQUENTIAL DAMAGES (INCLUDING DAMAGES FOR LOSS OF BUSINESS, LOSS OF PROFITS, LITIGATION, OR THE LIKE), WHETHER BASED UPON BREACH OF CONTRACT, BREACH OF WARRANTY, TORT (INCLUDING NEGLIGENCE), PRODUCT LIABILITY OR OTHERWISE, EVEN IF ADVISED OF THE POSSIBILITY OF SUCH DAMAGES. THE FOREGOING NEGATION OF DAMAGES IS A FUNDAMENTAL ELEMENT OF THE USE OF THE CONTENTS HEREOF, AND THESE CONTENTS WOULD NOT BE PUBLISHED BY TIA WITHOUT SUCH LIMITATIONS.

# OPTICAL FIBER CABLING COMPONENTS STANDARD

## Table of Contents

FOREWORD .....	iv
1 SCOPE .....	1
2 NORMATIVE REFERENCES .....	1
3 DEFINITIONS, ABBREVIATIONS AND ACRONYMS, UNITS OF MEASURE .....	2
3.1 General .....	2
3.2 Definitions .....	2
3.3 Abbreviations and acronyms .....	5
3.4 Units of measure .....	5
4 OPTICAL FIBER CABLE .....	6
4.1 General .....	6
4.2 Cable transmission performance .....	6
4.3 Physical requirements .....	6
4.3.1 Inside plant cable .....	6
4.3.2 Indoor-outdoor cable .....	7
4.3.3 Outside plant cable .....	7
4.3.4 Drop cable .....	7
5 CONNECTING HARDWARE .....	8
5.1 General .....	8
5.2 Connectors and adapters .....	8
5.2.1 Duplex connectors .....	8
5.2.1.1 Physical design .....	8
5.2.1.2 Performance .....	8
5.2.1.3 Keying and fiber positions .....	8
5.2.1.3.1 568SC Connector .....	8
5.2.1.3.2 Other duplex connectors .....	9
5.2.2 Array connectors .....	9
5.2.2.1 Physical design .....	9
5.2.2.2 Performance .....	9
5.2.2.3 Keying and fiber positions .....	9
5.2.2.4 Adapters .....	10
5.2.2.4.1 Type-A adapters .....	10
5.2.2.4.2 Type-B adapters .....	10
5.2.3 Multimode and single-mode connector and adapter identification .....	11
5.3 Optical fiber splice .....	11
5.4 Housings for cable terminations .....	11
5.4.1 General .....	11
5.4.2 Centralized cabling .....	11
6 OPTICAL FIBER PATCH CORDS AND OPTICAL FIBER TRANSITIONS .....	12
6.1 General .....	12
6.2 Patch cord cable .....	12
6.3 Patch cord connectors .....	12
6.4 Termination configuration .....	12
6.4.1 Simplex .....	12
6.4.2 Duplex .....	12
6.4.2.1 A-to-B duplex patch cord .....	12
6.4.2.2 A-to-A duplex patch cord .....	12

**ANSI/TIA-568-C.3**

6.4.3 Array..... 13

6.4.3.1 General..... 13

6.4.3.2 Array patch cord..... 13

6.4.3.2.1 Type-A array patch cord..... 13

6.4.3.2.2 Type-B array patch cord..... 14

6.4.3.2.3 Type-C array patch cord..... 15

6.5 Optical fiber transition..... 15

ANNEX A (NORMATIVE) OPTICAL FIBER CONNECTOR PERFORMANCE SPECIFICATIONS ..... 17

A.1 Introduction..... 17

A.2 Intermateability requirements..... 17

A.3 Test samples ..... 17

A.3.1 Connector samples ..... 17

A.3.1.1 Array connector samples..... 17

A.3.1.2 Mechanical loading samples ..... 17

A.3.1.3 Test samples with furcation points ..... 17

A.4 Performance requirements..... 17

A.4.1 Visual and mechanical inspections..... 17

A.4.2 Attenuation ..... 18

A.4.3 Return loss ..... 18

A.4.4 Low temperature ..... 18

A.4.5 Temperature life ..... 18

A.4.6 Humidity ..... 19

A.4.7 Impact ..... 19

A.4.8 Strength of coupling mechanism..... 19

A.4.9 Durability ..... 20

A.4.10 Cable retention..... 20

A.4.11 Flex..... 21

A.4.12 Twist..... 21

ANNEX B (INFORMATIVE) BIBLIOGRAPHY AND REFERENCES..... 22



**List of Tables**

Table 1 - Optical fiber cable transmission performance parameters ..... 6  
Table 2 - Type-A array patch cord fiber sequence..... 13  
Table 3 - Type-B array patch cord fiber sequence..... 14  
Table 4 - Type-C array patch cord fiber sequence..... 15

**List of Figures**

Figure 1 - Illustrative relationship between the ANSI/TIA-568-C Series and other relevant TIA standards..... v  
Figure 2 - Position A and B configuration of a 568SC..... 9  
Figure 3 - Example of Type-A MPO configuration ..... 10  
Figure 4 - Example of Type-B MPO configuration ..... 10  
Figure 5 - A-to-B duplex patch cord ..... 12  
Figure 6 - A-to-A duplex patch cord ..... 13  
Figure 7 - Type-A array patch cord (key-up to key-down) ..... 14  
Figure 8 - Type-B array patch cord (key-up to key-up) ..... 14  
Figure 9 - Type-C array patch cord (pair-wise flipped, key-up to key-down) ..... 15  
Figure 10 - Optical fiber transition ..... 16

## FOREWORD

(This foreword is not a part of this Standard.)

This Standard was developed by TIA Subcommittee TR-42.8.

### Approval of Standard

This Standard was approved by TIA Subcommittee TR-42.8, TIA Engineering Committee TR-42, and the American National Standards Institute (ANSI).

ANSI/TIA reviews standards every 5 years. At that time, standards are reaffirmed, withdrawn, or revised according to the submitted updates. Updates to be included in the next revision should be sent to the committee chair or to ANSI/TIA.

### Contributing Organizations

More than 30 organizations within the telecommunications industry contributed their expertise to the development of this Standard (including manufacturers, consultants, end users, and other organizations).

### Documents Superseded

This Standard replaces ANSI/TIA/EIA-568-B.3, published March, 2000, and ANSI/TIA/EIA-568-B.3-1, published April 2002.

### Significant technical changes from the previous edition

- Incorporates the performance specifications for 850 nm laser-optimized, 50/125  $\mu\text{m}$  multimode optical fiber cables previously found in ANSI/TIA/EIA-568-B.3-1.
- Provides specifications for indoor-outdoor cable including minimum bend radius and maximum pulling tensions.
- Includes array connector specifications.

### Relationship to other TIA standards and documents

The following are related standards regarding various aspects of structured cabling that were created under TIA TR42.

- ANSI/TIA-568-C.0, *Generic Telecommunications Cabling for Customer Premises*
- ANSI/TIA-568-C.1, *Commercial Building Telecommunications Cabling Standard*
- TIA-569-B, *Commercial Building Standard for Telecommunications Pathways and Spaces*
- ANSI/TIA-570-B, *Residential Telecommunications Infrastructure Standard*
- ANSI/TIA/EIA-606-A, *Administration Standard for Commercial Telecommunications Infrastructure*
- ANSI-J-STD-607-A, *Commercial Building Grounding (Earthing) and Bonding Requirements for Telecommunications*
- ANSI/TIA-758-A, *Customer-Owned Outside Plant Telecommunications Infrastructure Standard*
- ANSI/TIA/EIA-862, *Building Automation Systems Cabling Standard for Commercial Buildings*
- ANSI/TIA-942, *Telecommunications Infrastructure Standard for Data Centers*

Following is the schematic relationship between the ANSI/TIA-568-C series and other relevant standards.

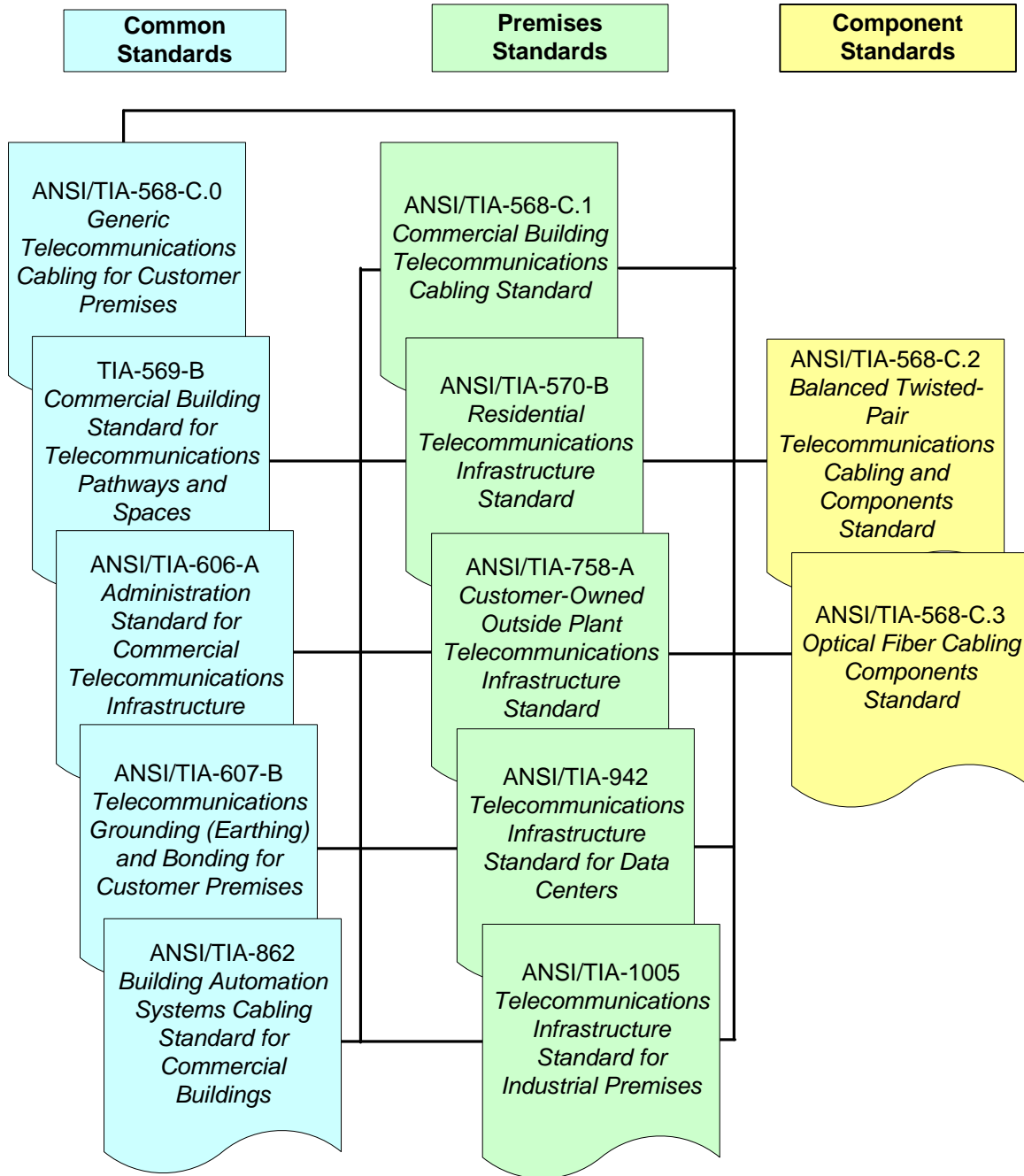

Figure 1 - Illustrative relationship between the ANSI/TIA-568-C Series and other relevant TIA standards

## **ANSI/TIA-568-C.3**

The following documents may be useful to the reader:

- a) *National Electrical Safety Code*<sup>®</sup> (NESC<sup>®</sup>) (IEEE C2-2007)
- b) *National Electrical Code*<sup>®</sup> (NEC<sup>®</sup>) (NFPA 70 2005)

Useful supplements to this Standard are BICSI's *Telecommunications Distribution Methods Manual*, the *Customer-owned Outside Plant Design Manual*, and the *Information Transport Systems Installation Manual*. These manuals provide practices and methods by which many of the requirements of this Standard are implemented.

Other references are listed in annex B.

### **Annexes**

Annex A is normative and is considered a requirement of this Standard. Annex B is informative and not considered a requirement of this Standard.

### **Introduction**

#### **Purpose**

The purpose of this Standard is to specify cable and component transmission performance requirements for premises optical fiber cabling. It is intended to be used by manufacturers. Users, designers and installers may also find this Standard useful. Additionally, this Standard is intended to be used as a reference by the suite of premises cabling standards listed in the Foreword.

#### **Specification of criteria**

Two categories of criteria are specified; mandatory and advisory. The mandatory requirements are designated by the word "shall"; advisory requirements are designated by the words "should", "may", or "desirable" which are used interchangeably in this Standard.

Mandatory criteria generally apply to protection, performance, administration and compatibility; they specify minimally acceptable requirements. Advisory criteria are presented when their attainment may enhance the general performance of the cabling system in all its contemplated applications.

A note in the text, table, or figure is used for emphasis or offering informative suggestions, or providing additional information.

#### **Metric equivalents of US customary units**

The dimensions in this Standard are metric or US customary with soft conversion to the other.

#### **Life of the Standard**

This Standard is a living document. The criteria contained in this Standard are subject to revisions and updating as warranted by advances in building construction techniques and telecommunications technology.

## 1 SCOPE

This Standard is applicable to premises optical fiber cabling components. Specified in this Standard are requirements for components, such as cable, connectors, connecting hardware and patch cords.

## 2 NORMATIVE REFERENCES

The following standards contain provisions that, through reference in this text, constitute provisions of this Standard. At the time of publication, the editions indicated were valid. All standards are subject to revision, and parties to agreements based on this Standard are encouraged to investigate the possibility of applying the most recent editions of the standards.

Fiber Optic Test Procedures (FOTPs):

- TIA/EIA-455-B-1998, *Standard Test Procedures for Fiber Optic Fibers, Cables, Transducers, Sensors, Connecting and Terminating Devices, and other Fiber Optic Components*
- ANSI/TIA/EIA-455-1-B-2003, *Cable Flexing for Fiber Optic Interconnecting Devices*
- ANSI/TIA/EIA-455-2-C-1998, *Impact Test Measurements for Fiber Optic Devices*
- ANSI/TIA/EIA-455-4-C-2002, *Fiber Optic Component Temperature Life Test*
- ANSI/TIA/EIA-455-5-C-2002, *Humidity Test Procedure for Fiber Optic Components*
- TIA-455-6-B-2003, *Cable Retention Test Procedure for Fiber Optic Cable Interconnecting Devices*
- ANSI/TIA/EIA-455-8-2000, *Measurement of Splice or Connector Loss and Reflectance Using an OTDR*
- TIA-455-13-A-2002, *Visual and Mechanical Inspection of Fiber Optic Components, Devices, and Assemblies*
- TIA-455-21-A-2002, *Mating Durability for Fiber Optic Interconnecting Devices*
- ANSI/TIA/EIA-455-34-A-2002, *Interconnection Device Insertion Loss Test*
- TIA-455-36-A-2002, *Twist Test for Fiber Optic Connecting Devices*
- ANSI/TIA-455-78-B-2002, *Optical Fibres Part 1-40: Measurement Methods and Test Procedures – Attenuation*
- TIA-455-107-A-2004, *Determination of Component Reflectance or Link/System Return Loss Using a Loss Test Set*
- ANSI/TIA/EIA-455-171-A-2001, *Attenuation by Substitution Measurement for Short-Length Multimode Graded-Index and Single-Mode Optical Fiber Cable Assemblies*
- ANSI/TIA/EIA-455-185-1999, *Strength of Coupling Mechanism for Fiber Optic Interconnecting Devices*
- ANSI/TIA/EIA-455-188-2001, *Low-Temperature Testing of Fiber Optic Components*

Cable standards:

- TIA-492AAAA-A-2002, *Detail Specification for 62.5  $\mu\text{m}$  Core Diameter/125  $\mu\text{m}$  Cladding Diameter Class Ia Graded-Index Multimode Optical Fibers*
- TIA-492AAAB-2002, *Detail Specification for 50  $\mu\text{m}$  Core Diameter/125  $\mu\text{m}$  Cladding Diameter Class Ia Multimode, Graded-Index Optical Waveguide Fibers*
- TIA-492AAAC-A-2003, *Detail Specification for 850-nm Laser-Optimized, 50- $\mu\text{m}$  Core Diameter/125- $\mu\text{m}$  Cladding Diameter Class 1a Graded-Index Multimode Optical Fibers*
- TIA-492CAAA-2002, *Detail Specification for Class IVa Dispersion-Unshifted Single-mode Optical Fibers*
- TIA-492CAAB-2005, *Detail Specification for Class IVa Dispersion-Unshifted Single-mode Optical Fibers With Low Water Peak*
- ANSI/TIA-598-C-2005, *Optical Fiber Cable Color Coding*
- TIA 472C000-B/ICEA S-83-596-2001, *Fiber Optic Premises Distribution Cable*
- TIA 472D000-B/ICEA S-87-640-1999, *Fiber Optic Outside Plant Communications Cable*
- TIA 472E000/ICEA S-104-696-2003, *Standard For Indoor-Outdoor Optical Cable*
- TIA 472F000/ICEA S-110-717-2003, *Optical Drop Cables*

### 3 DEFINITIONS, ABBREVIATIONS AND ACRONYMS, UNITS OF MEASURE

#### 3.1 General

For the purposes of this Standard, the following definitions, acronyms, abbreviations and units of measure apply.

#### 3.2 Definitions

**adapter, optical fiber:** A mechanical device designed to align and join two optical fiber connectors (plugs) to form an optical connection.

**adapter; optical fiber duplex:** A mechanical device designed to align and join two duplex optical fiber connectors (plugs) to form an optical duplex connection.

**adapter; optical fiber array:** A mechanical device designed to align and join two array optical fiber connectors (plugs) to form an optical array connection.

**administration:** The method for labeling, identification, documentation and usage needed for installation, moves, additions and changes of the telecommunications infrastructure.

**array connector (multi-fiber connector):** A single ferrule connector that contains multiple optical fibers arranged in a row or in rows and columns.

**A-to-B patch cord, optical fiber:** A duplex patch cord that connects Position A on one end of the patch cord to Position B on the other end of the patch cord.

**A-to-A patch cord, optical fiber:** A duplex patch cord that connects Position A on one end of the patch cord to Position A on the other end of the patch cord.

**array patch cord:** A length of optical fiber cable with an array connector on each end.

**attenuation:** The decrease in magnitude of transmission signal strength between points, expressed in dB as the ratio of output to input signal level.

**backbone:** A facility (e.g., pathway, cable or bonding conductor) for Cabling Subsystem 2 and Cabling Subsystem 3.

**backbone cable:** See **backbone**.

**bonding:** The permanent joining of metallic parts to form an electrically conductive path that will ensure electrical continuity and the capacity to conduct safely any current likely to be imposed.

**cable:** An assembly of one or more insulated conductors or optical fibers, within an enveloping sheath.

**cabbling:** A combination of all cables, jumpers, cords, and connecting hardware.

**Cabling Subsystem 1:** Cabling from the equipment outlet to Distributor A, Distributor B, or Distributor C.

**Cabling Subsystem 2:** Cabling between Distributor A and either Distributor B or Distributor C (if Distributor B is not implemented).

**Cabling Subsystem 3:** Cabling between Distributor B and Distributor C.

**campus:** The buildings and grounds having legal contiguous interconnection.

**centralized cabling:** A cabling configuration from an equipment outlet to a centralized cross-connect in the same building using a continuous cable, an interconnect, or a splice.

**channel:** The end-to-end transmission path between two points at which application-specific equipment is connected.

**commercial building:** A building or portion thereof that is intended for office use.

**connecting hardware:** A device providing mechanical cable terminations.

**connector (plug), duplex; optical fiber:** A remateable device that terminates two fibers and mates with a duplex receptacle.

**cord (telecommunications):** An assembly of cord cable with a plug on one or both ends.

**cord cable:** A cable used to construct patch, work area, and equipment cords.

**cross-connect:** A facility enabling the termination of cable elements and their interconnection or cross-connection.

**cross-connection:** A connection scheme between cabling runs, subsystems, and equipment using patch cords or jumpers that attach to connecting hardware on each end.

**customer premises:** Building(s), grounds and appurtenances (belongings) under the control of the customer.

**data:** Electronically encoded information.

**data center:** A building or portion of a building whose primary function is to house a computer room and its support areas.

**distribution frame:** A structure with terminations for connecting the cabling of a facility in such a manner that interconnection or cross-connections may be readily made.

(1) **main:** When the structure is located at the entrance facility or main cross-connect and serving the building or campus.

(2) **intermediate:** When the structure is located between the main cross-connect and the telecommunications room.

**Distributor A:** Optional connection facility in a hierarchical star topology that is cabled between the equipment outlet and Distributor B or Distributor C.

**Distributor B:** Optional intermediate connection facility in a hierarchical star topology that is cabled to Distributor C.

**Distributor C:** Central connection facility in a hierarchical star topology.

**drop cable:** Cable linking a drop terminal (e.g. from a service provider) to a premises terminal.

**earthing:** See **grounding**.

**end user:** The owner or user of the premises cabling system.

**equipment cord:** See **cord**.

**equipment outlet:** Outermost connection facility in a hierarchical star topology.

**fiber optic:** See **optical fiber**.

**furcation point:** The point in a cable assembly that either joins two different cable constructions or where cable construction is altered (often where a cable assembly divides into branches).

**grounding:** The act of creating a ground.

**infrastructure (telecommunications):** A collection of those telecommunications components, excluding equipment, that together provide the basic support for the distribution of information within a building or campus.

**insertion loss:** The signal loss resulting from the insertion of a component, or link, or channel, between a transmitter and receiver (often referred to as attenuation).

**interconnection:** A connection scheme that employs connecting hardware for the direct connection of a cable to another cable without a patch cord or jumper.

**jumper:** 1) An assembly of twisted-pairs without connectors, used to join telecommunications circuits/links at the cross-connect. 2) A length of optical fiber cable with a connector plug on each end.

## ANSI/TIA-568-C.3

**keying:** The mechanical feature of a connector system that guarantees correct orientation of a connection, or prevents the connection to a jack, or to an optical fiber adapter of the same type intended for another purpose.

**link:** A transmission path between two points, not including equipment and cords.

**mode:** A path of light in an optical fiber.

**multi-fiber connector:** See **array connector**.

**multimode optical fiber:** An optical fiber that carries many paths of light.

**optical fiber:** Any filament made of dielectric materials that guides light.

**optical fiber cable:** An assembly consisting of one or more optical fibers.

**outlet/connector (telecommunications):** An equipment outlet used in commercial and residential cabling.

**outside plant:** Telecommunications infrastructure designed for installation exterior to buildings.

**patch cord:** 1) A length of cable with a plug on one or both ends. 2) A length of optical fiber cable with a connector on each end.

**pathway:** A facility for the placement of telecommunications cable.

**pigtail:** One or more conductors or fibers with only one end terminated.

**plug:** A male telecommunications connector.

**pull strength:** See **pull tension**.

**pull tension:** The pulling force that can be applied to a cable.

**return loss:** A ratio expressed in dB of the power of the outgoing signal to the power of the reflected signal.

**service provider:** The operator of any service that furnishes telecommunications content (transmissions) delivered over access provider facilities.

**single-mode optical fiber:** An optical fiber that carries only one path of light.

**splice:** A joining of conductors, meant to be permanent.

**star topology:** A topology in which telecommunications cables are distributed from a central point.

**telecommunications:** Any transmission, emission, and reception of signs, signals, writings, images, and sounds, that is, information of any nature by cable, radio, optical, or other electromagnetic systems.

**telecommunications outlet:** An assembly of components consisting of one or more connectors mounted on a faceplate, housing or supporting bracket.

**terminal:** (1) a point at which information may enter or leave a communications network. (2) The input-output associated equipment. (3) A device by means of which wires may be connected to each other.

**termination:** This term is outmoded. See **connecting hardware**.

**topology:** The physical or logical arrangement of a telecommunications system.

**transition, optical fiber:** An assembly of optical fibers and connectors, with an array connector on one end and simplex or duplex connectors on other end.



### 3.3 Abbreviations and acronyms

ANSI	American National Standards Institute
CATV	community antenna television
EIA	Electronic Industries Alliance
FOCIS	Fiber Optic Connector Intermateability Standard
ICEA	Insulated Cable Engineers Association
IEC	International Electrotechnical Commission
IEEE	The Institute of Electrical and Electronics Engineers
ISO	International Organization for Standardization
N/A	not applicable
NEC <sup>®</sup>	National Electrical Code <sup>®</sup>
NESC <sup>®</sup>	National Electrical Safety Code <sup>®</sup>
NFPA	National Fire Protection Association
OTDR	optical time domain reflectometer
TDMM	Telecommunications Distribution Methods Manual
TIA	Telecommunications Industry Association
TSB	Telecommunications System Bulletin

### 3.4 Units of measure

dB	decibel
°C	degrees Celsius
°F	degrees Fahrenheit
ft	feet, foot
in	inch
km	kilometer
lbf	pound-force
m	meter
MHz	megahertz
mm	millimeter
N	Newton
nm	nanometer
μm	micrometer (micron)

## 4 OPTICAL FIBER CABLE

### 4.1 General

This clause contains the performance specifications for the optical fiber cables recognized in premises cabling standards.

### 4.2 Cable transmission performance

Each cabled fiber shall meet the performance specifications of table 1.

**Table 1 - Optical fiber cable transmission performance parameters**

Optical fiber and cable type <sup>2</sup>	Wavelength (nm)	Maximum attenuation (dB/km)	Minimum overfilled modal bandwidth-length product (MHz·km) <sup>1</sup>	Minimum effective modal bandwidth-length product (MHz·km) <sup>1</sup>
62.5/125 μm Multimode TIA 492AAAA (OM1)	850	3.5	200	Not Required
	1300	1.5	500	Not Required
50/125 μm Multimode TIA 492AAAB (OM2)	850	3.5	500	Not Required
	1300	1.5	500	Not Required
850 nm Laser-Optimized 50/125 μm Multimode TIA 492AAAC (OM3)	850	3.5	1500	2000
	1300	1.5	500	Not Required
Single-mode Indoor-Outdoor TIA 492CAAA (OS1) TIA 492CAAB (OS2) <sup>3</sup>	1310	0.5	N/A	N/A
	1550	0.5	N/A	N/A
Single-mode Inside Plant TIA 492CAAA (OS1) <sup>3</sup> TIA 492CAAB (OS2) <sup>3</sup>	1310	1.0	N/A	N/A
	1550	1.0	N/A	N/A
Single-mode Outside Plant TIA 492CAAA (OS1) <sup>3</sup> TIA 492CAAB (OS2) <sup>3</sup>	1310	0.5	N/A	N/A
	1550	0.5	N/A	N/A
NOTES				
1 - The bandwidth-length product, as measured by the fiber manufacturer, can be used to demonstrate compliance with this requirement.				
2 - The fiber designation (OM1, OM2, OM3, OS1 and OS2) corresponds to the designation of ISO/IEC 11801 or ISO/IEC 24702.				
3 - OS2 is commonly referred to as "low water peak" single-mode fiber and is characterized by having a low attenuation coefficient in the vicinity of 1383 nm.				

### 4.3 Physical requirements

Optical fiber cables shall contain one or multiple fiber types chosen from table 1. Individual fibers and groups of fibers shall be identifiable in accordance with ANSI/TIA-598-C.

#### 4.3.1 Inside plant cable

Inside plant optical fiber cables shall comply with the testing and test methods requirements in TIA 472C000-B/ICEA S-83-596 for its cable design.

Cables with four or fewer fibers intended for Cabling Subsystem 1 shall support a bend radius of 25 mm (1 in) when not subject to tensile load. Cables with four or fewer fibers intended to be pulled through pathways during installation shall support a bend radius of 50 mm (2 in) under a pull load of 220 N (50 lbf). All other inside plant cables shall support a bend radius of 10 times the cable outside diameter when not subject to tensile load, and 20 times the cable outside diameter when subject to

tensile loading up to the cable's rated limit.

#### **4.3.2 Indoor-outdoor cable**

Indoor-outdoor optical fiber cables shall comply with the testing and test methods requirements in TIA 472E000/ICEA S-104-696 for its cable design.

Indoor-outdoor cable shall have a minimum pull strength of 2670 N (600 lbf) for cables with more than 12 fibers, and a minimum pull strength of 1335 N (300 lbf) for cables with less than or equal to 12 fibers.

Indoor-outdoor optical fiber cables shall support a bend radius of 10 times the cable outside diameter when not subject to tensile load, and 20 times the cable outside diameter when subject to tensile loading up to the cable's rated limit.

#### **4.3.3 Outside plant cable**

Outside plant optical fiber cables shall comply with the testing and test methods requirements in TIA 472D000-B/ICEA S-87-640 for its cable design.

Outdoor cable shall have a minimum pull strength of 2670 N (600 lbf).

Outdoor optical fiber cables shall support a bend radius of 10 times the cable outside diameter when not subject to tensile load, and 20 times the cable outside diameter when subject to tensile loading up to the cable's rated limit.

#### **4.3.4 Drop cable**

Optical fiber drop cables shall comply with the testing and test methods requirements in TIA 472F000/ICEA S-110-717 for its cable design

Drop cable shall have a minimum pull strength of 1335 N (300 lbf) for cables installed by pulling, and 440 N (100 lbf) for cables that are direct-buried, placed by trenching, or blown into ducts.

Drop cable shall support a bend radius of 10 times the cable outside diameter when not subject to tensile load, and 20 times the cable outside diameter when subject to tensile loading up to the cables rated limit. Non-circular cable bend diameter requirements are to be determined using the minor axis as the cable diameter and bending in the direction of the preferential bend.

## 5 CONNECTING HARDWARE

### 5.1 General

This clause contains the performance specifications for optical fiber connectors, connecting hardware and splices. These requirements apply to connecting hardware used for cable terminations in Distributors.

Connector designs meeting the requirements of clause 5.2 shall be used. The duplex SC connector and adapter (referred to as the 568SC), and the MPO connector and adapter are used for illustrative purposes in this Standard.

### 5.2 Connectors and adapters

#### 5.2.1 Duplex connectors

##### 5.2.1.1 Physical design

Connector designs shall meet the requirements of the corresponding TIA Fiber Optic Connector Intermateability Standard (FOCIS). For example, the 568SC connector and adapter shall meet the requirements of TIA-604-3; designation FOCIS 3P-0-2-1-1-0 for single-mode plugs, designation FOCIS 3P-0-2-1-4-0 for multimode plugs, and designation FOCIS 3A-2-1-0 for adapters.

##### 5.2.1.2 Performance

The performance of the connector designs shall meet the requirements specified in annex A.

##### 5.2.1.3 Keying and fiber positions

The two fiber positions in a duplex connector and the corresponding adapter shall be referred to as Position A and Position B.

##### 5.2.1.3.1 568SC Connector

Figure 2 shows the locations of Position A and Position B in the 568SC connector and adapter with respect to the keys and keyways. As the figure illustrates, the 568SC adapter shall perform a pair-wise crossover between connectors. Additionally, the plane (frontal) view inset in Figure 2 shows Position A and Position B in the two possible horizontal and two possible vertical orientations. The shading used in Figure 2 is for clarification only and is not a specified identification scheme. The two positions of the 568SC adapter shall be identified as Position A and Position B by using the letter designators A and B respectively. Labeling may be either field or factory installed.

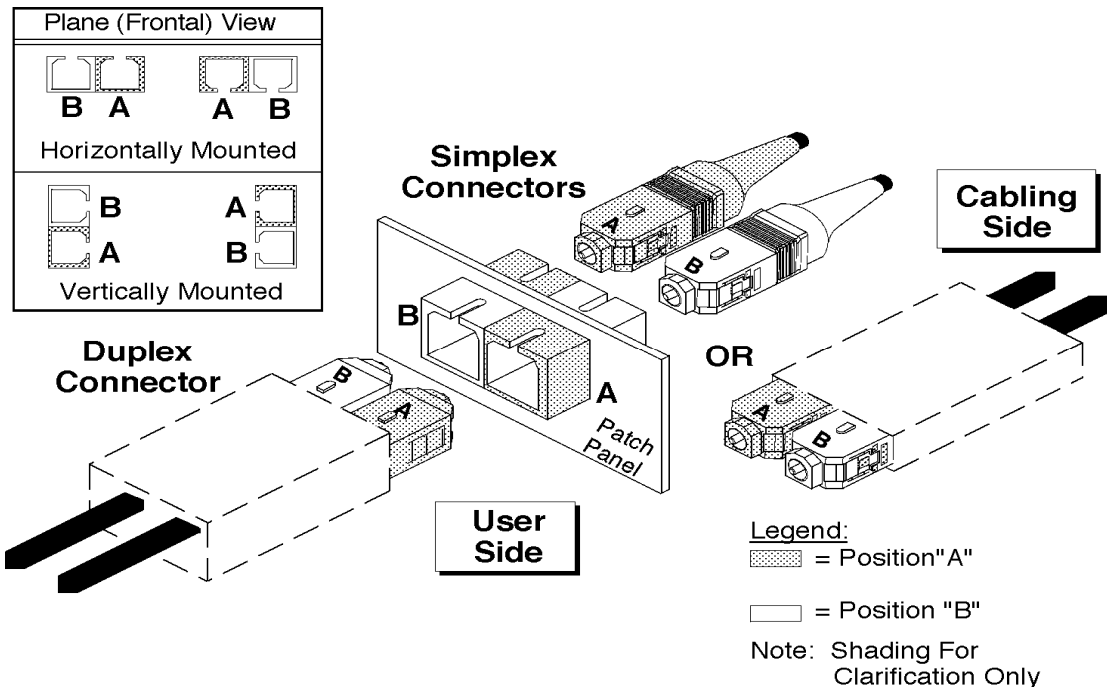

Figure 2 - Position A and B configuration of a 568SC

#### 5.2.1.3.2 Other duplex connectors

Alternate connector designs shall employ similar labeling and identification schemes to that of the 568SC. Position A and Position B on alternate duplex connector designs shall be in the same position as the 568SC in Figure 2. For alternate connector designs utilizing latches, the latch defines the positioning in the same manner as the key and keyways.

### 5.2.2 Array connectors

#### 5.2.2.1 Physical design

Connector designs shall meet the requirements of the corresponding TIA Fiber Optic Connector Intermateability Standard (FOCIS). For example, the MPO connector and adapter shall meet the requirements of TIA-604-5 (FOCIS 5).

Single-mode array connectors typically use angled contact ferrules.

#### 5.2.2.2 Performance

The performance of the connector designs shall meet the requirements specified in annex A.

#### 5.2.2.3 Keying and fiber positions

The fiber positions in an array connector shall be referred to as Position 1 through N, where N is the number of fiber positions in the connector. Figure 3 and figure 4 illustrate the locations of Position 1 through Position 12 in the array connector and adapter with respect to the keys and keyways. As the figures reveal, the array adapter shall perform an array-wise crossover of fibers relative to the array fiber numbering convention for key-up to key-up configurations and perform a straight through interconnect for key-up to key-down configurations.

### 5.2.2.4 Adapters

There are two types of array adapters, Type-A and Type-B. Type-A adapters shall be identified to distinguish them from Type-B adapters.

#### 5.2.2.4.1 Type-A adapters

Type-A adapters shall mate two array connectors with the connector keys key-up to key-down. The complete designation for a Type-A MPO adapter is FOCIS 5 A-1-0, as defined in ANSI/TIA/EIA-604-5.

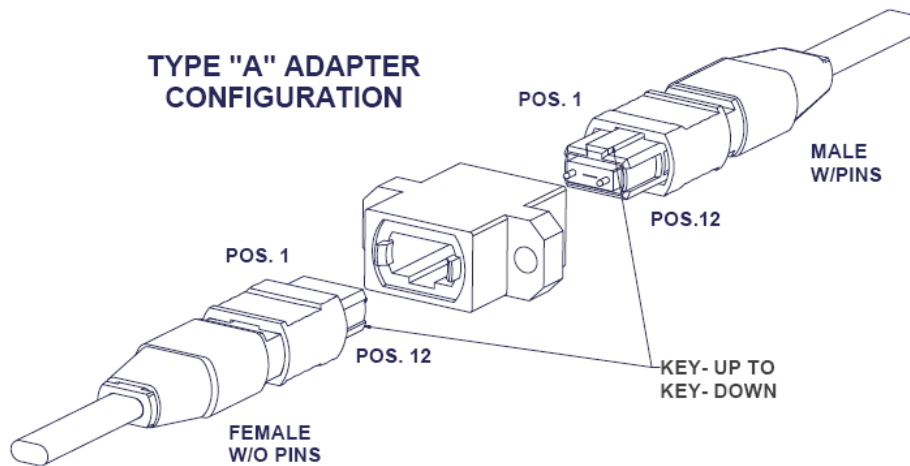

Figure 3 - Example of Type-A MPO configuration

#### 5.2.2.4.2 Type-B adapters

Type-B adapters shall mate two array connectors with the connector keys key-up to key-up (keys aligned). The complete designation for a Type-B MPO adapter is FOCIS 5 A-2-0, as defined in ANSI/TIA/EIA-604-5.

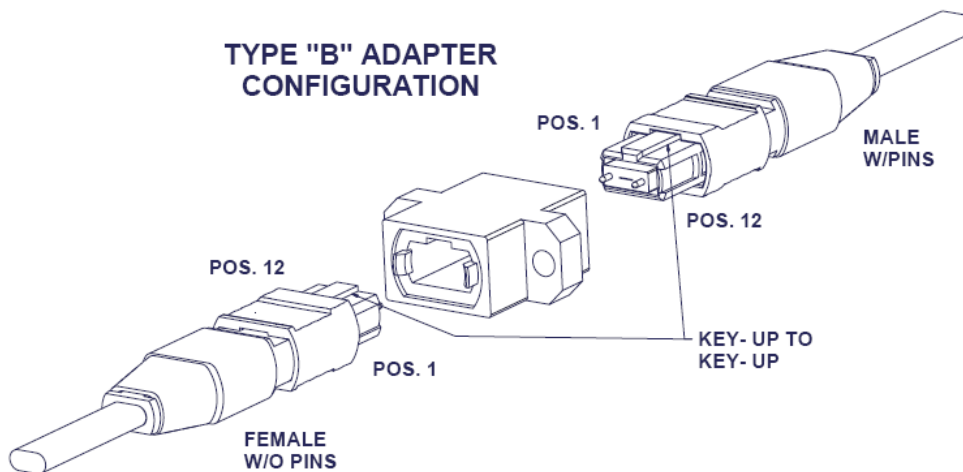

Figure 4 - Example of Type-B MPO configuration

### 5.2.3 Multimode and single-mode connector and adapter identification

Unless color coding is used for some other purpose, the connector strain relief and adapter housing should be identifiable by the following colors:

- a) 850 nm laser-optimized 50/125  $\mu\text{m}$  fiber – aqua
- b) 50/125  $\mu\text{m}$  fiber – black
- c) 62.5/125  $\mu\text{m}$  fiber – beige
- d) Single-mode fiber – blue
- e) Angled contact ferrule single-mode connectors – green

In addition, unless color coding is used for some other purpose, the connector plug body should be generically identified by the following colors, where possible:

- a) Multimode – beige, black or aqua
- b) Single-mode – blue
- c) Angled contact ferrule single-mode connectors – green

### 5.3 Optical fiber splice

Optical fiber splices, fusion or mechanical, shall not exceed a maximum optical insertion loss of 0.3 dB when measured in accordance with ANSI/EIA/TIA-455-34-A, Method A (factory testing) or ANSI/TIA-455-78-B (field testing).

Optical fiber splices, fusion or mechanical, shall have a minimum return loss of 20 dB for multimode, 26 dB for single-mode and 55 dB for single-mode broadband analog video (CATV), when measured in accordance with TIA/EIA-455-107-A.

### 5.4 Housings for cable terminations

#### 5.4.1 General

Housings for cable terminations used to join optical fiber cabling shall provide a means to:

- a) join the fibers using either re-mateable connectors or splices;
  - 1) re-mateable connectors shall meet the requirements of clause 5.2.
  - 2) splices (fusion or mechanical) shall meet the requirements of clause 5.3.
- b) join fibers singly, in pairs, or arrays;
- c) identify each joining position uniquely;
- d) allow removal of existing connections, and the addition of new connections;
- e) store and identify non-connected fibers;
- f) accommodate the addition of cables;
- g) allow access to optical fiber cabling for testing;
- h) protect connections against accidental contact with foreign objects that may disturb optical continuity;
- i) handle optical fiber cables and patch cords, and promote their orderly management;
- j) mount on walls, in racks, or on other types of distribution frames and standard mounting hardware; and,
- k) maintain a bend radius not less than the manufacturer's recommendations.

An equipment outlet shall provide the capacity and means to maintain fiber bend radius of not less than 25 mm (1 in) and to house a minimum of two terminated optical fibers.

The manufacturer shall provide installation instructions and may provide design recommendations to accomplish the above requirements.

#### 5.4.2 Centralized cabling

Housings for Distributor A used for centralized optical fiber cabling shall provide a means to migrate from an interconnection or splice to a cross-connection.

## 6 OPTICAL FIBER PATCH CORDS AND OPTICAL FIBER TRANSITIONS

### 6.1 General

Patch cords connect optical fiber links at cross connects, interconnects, and telecommunications equipment. Optical fiber transitions connect cabling from an array connector to simplex or duplex connectors.

NOTE - Requirements for application-specific assemblies are outside the scope of this Standard.

### 6.2 Patch cord cable

The patch cord shall contain the same number of fibers as the connector used (e.g., duplex connectors using duplex patch cord cable), be of an indoor construction, and meet the requirements of clauses 4.2 and 4.3.1.

### 6.3 Patch cord connectors

The patch cord connectors shall meet the requirements of clause 5.2.

### 6.4 Termination configuration

#### 6.4.1 Simplex

A single fiber cable with simplex connector terminations that comply with clauses 6.2 and 6.3 comprise a simplex patch cord.

#### 6.4.2 Duplex

##### 6.4.2.1 A-to-B duplex patch cord

A-to-B duplex patch cords shall be of an orientation such that Position A connects to Position B on one fiber, and Position B connects Position A (figure 5). Each end of the patch cord shall indicate Position A and Position B if the connector can be separated into its simplex components. For connector designs utilizing latches, the latch defines the positioning in the same manner as the keys.

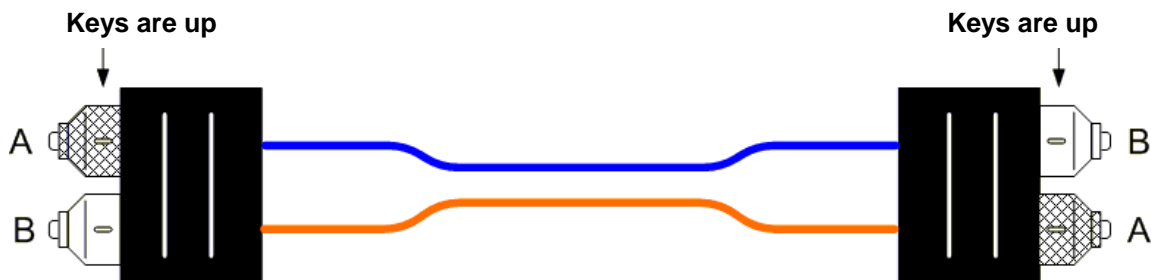

NOTE - SC connectors are shown, but this assembly may be built using any duplex single-fiber connectors or connectors with two fixed fibers that meet the requirements of a published Fiber Optic Connector Intermateability Standard (FOCIS).

Figure 5 - A-to-B duplex patch cord

##### 6.4.2.2 A-to-A duplex patch cord

A-to-A duplex patch cords shall be built as specified in clause 6.4.2.1, except Position A shall be connected to Position A and Position B connected to Position B (figure 6).

A-to-A patch cords do not reverse the fiber positions. The A-to-A duplex patch cords shall be of an orientation such that Position A goes to Position A on one fiber, and Position B goes to Position B on the other fiber (figure 6). The A-to-A duplex patch cords shall be clearly identified (by color or prominent labeling) to distinguish them from A-to-B patch cords.



NOTE – A-to-A patch cords are not commonly deployed and should be used only when necessary as part of a polarity method (See ANSI/TIA-568-C.0).

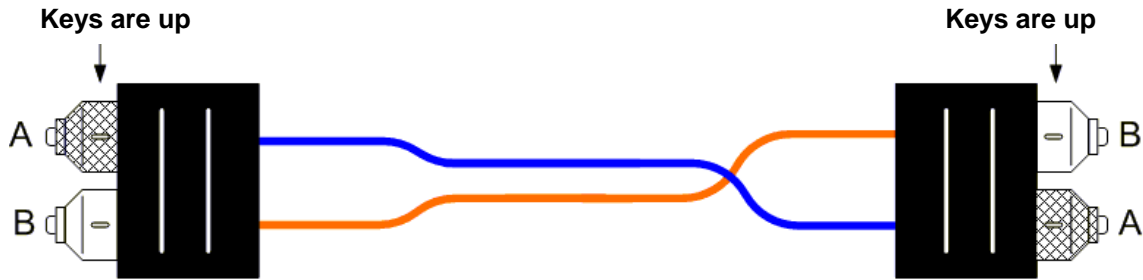

NOTE - SC connectors are shown, but this assembly may be built using any duplex single-fiber connectors or connectors with two fixed fibers that meet the requirements of a published Fiber Optic Connector Intermateability Standard (FOCIS).

**Figure 6 - A-to-A duplex patch cord**

### 6.4.3 Array

#### 6.4.3.1 General

Array system connectivity methods require a specific combination of components (array patch cord, optical fiber transitions, duplex patch cord) to maintain polarity. Some of the components are common to other connectivity methods such as duplex systems.

#### NOTES

- 1 - The patch cords shown in figures 7, 8 and 9 are unpinned on both ends. In some instances, such as when supporting parallel signals, it may be necessary to use a combination of unpinned and pinned connectors on cables and patch cords.
- 2 - See ANSI/TIA-568-C.0 for guidance on usage of polarity methods.

#### 6.4.3.2 Array patch cord

The patch cords should be clearly identified.

##### 6.4.3.2.1 Type-A array patch cord

As shown in figure 7, a Type-A array patch cord has a sequential number assigned to each fiber as follows:

- a) On one end of the patch cord, the fibers are fixed within the array connector in consecutive number (1,2,3,4...12) from left to right as viewed looking at the end-face of the connector with the connector key up (see table 2).
- b) On the other end of the patch cord, the fibers are fixed within the array connector also in consecutive number (1,2,3,4...12) from left to right as viewed looking at the end-face of the connector with the connector key up (see table 2).

**Table 2 - Type-A array patch cord fiber sequence**

Near / Far End	Fiber Sequence (viewing the end face of the connector with key up)											
	Near	1	2	3	4	5	6	7	8	9	10	11
Far	1	2	3	4	5	6	7	8	9	10	11	12



Figure 7 - Type-A array patch cord (key-up to key-down)

6.4.3.2.2 Type-B array patch cord

As shown in figure 8, a Type-B array patch cord has a sequential number assigned to each fiber as follows:

- a) On one end of the patch cord, the fibers are fixed within the array connector in consecutive number (1,2,3,4...12) from left to right as viewed looking at the end-face of the connector with the connector key up (see table 3).
- b) On the other end of the patch cord, the fibers are fixed within the array connector in reverse consecutive number (12,11,10,9...1) from left to right as viewed looking at the end-face of the connector with the connector key up (see table 3).

Table 3 - Type-B array patch cord fiber sequence

Near / Far End	Fiber Sequence (viewing the end face of the connector with key up)											
	Near	1	2	3	4	5	6	7	8	9	10	11
Far	12	11	10	9	8	7	6	5	4	3	2	1



Figure 8 - Type-B array patch cord (key-up to key-up)

### 6.4.3.2.3 Type-C array patch cord

As shown in figure 9, Type-C array patch cord has a sequential number assigned to each fiber as follows:

- On one end of the patch cord, the fibers are fixed within the array connector in consecutive number (1,2,3,4...12) from left to right as viewed looking at the end-face of the connector with the connector key up (see table 4).
- On the other end of the patch cord, the fibers are pair-wise flipped within the array connector (2,1; 4,3; 6,5...12,11) from left to right as viewed looking at the end-face of the connector with the connector key up (see table 4).

**Table 4 - Type-C array patch cord fiber sequence**

Near / Far End	Fiber Sequence (viewing the end face of the connector with key up)											
Near	1	2	3	4	5	6	7	8	9	10	11	12
Far	2	1	4	3	6	5	8	7	10	9	12	11

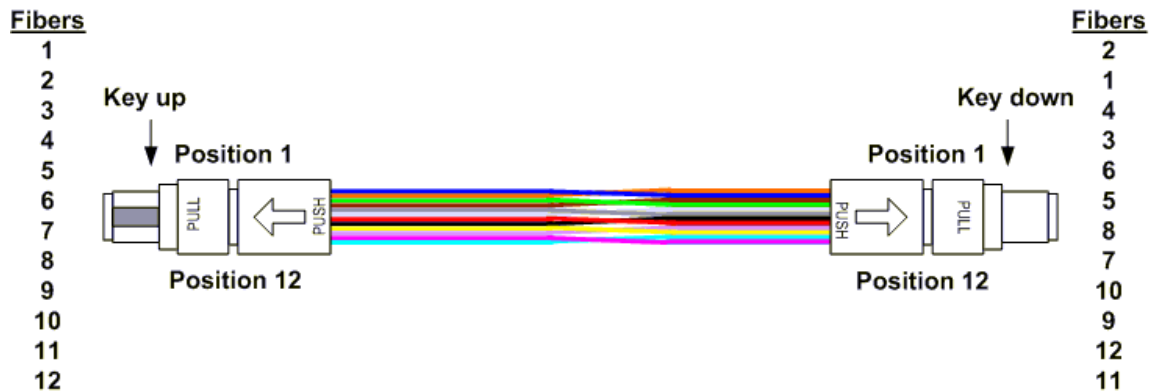
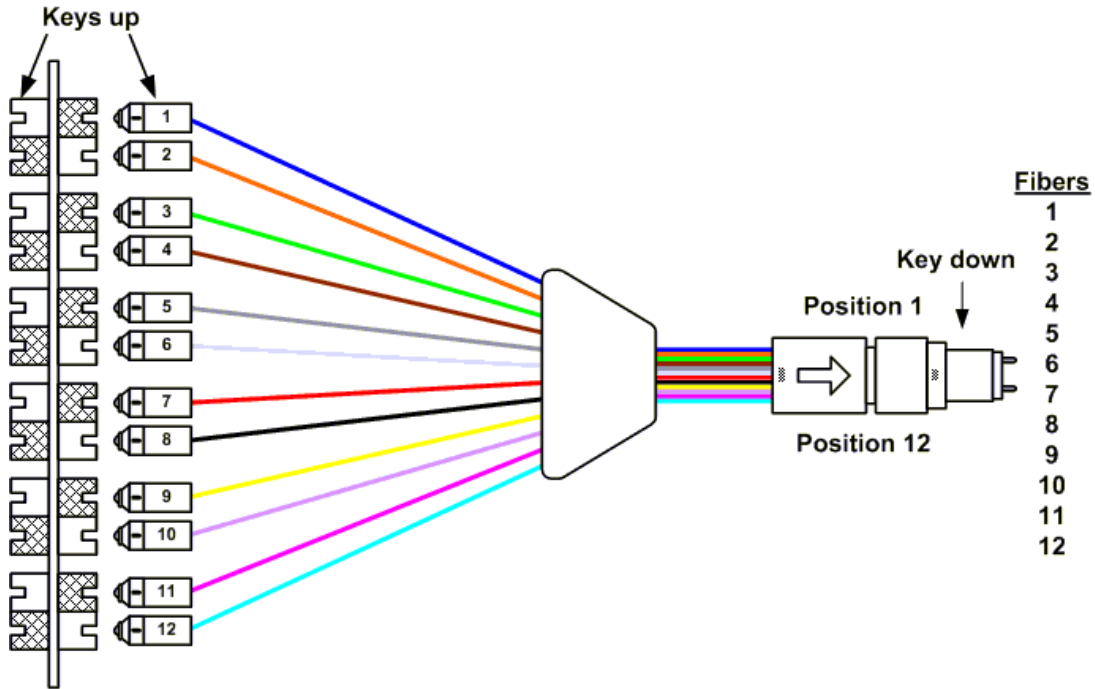

**Figure 9 - Type-C array patch cord (pair-wise flipped, key-up to key-down)**

### 6.5 Optical fiber transition

As shown in figure 10, optical fiber transitions have a sequential number assigned to each fiber as follows:

- On one end of the optical fiber transition the fibers are fixed within the array connector in consecutive number (1,2,3,4...12) from left to right as viewed looking at the end-face of the connector with the connector key up.
- On the other end of the optical fiber transition the fibers are fixed within the connectors in consecutive numbering (1,2; 3,4; 5,6...11,12) from left to right as viewed looking at the end-face of the connectors with the connector keys up.



NOTES

- 1 - SC connectors are illustrated; however this assembly may use single-fiber connectors or connectors with two fixed fibers.
- 2 - For ease of illustration, this optical fiber transition is shown with duplex adapters, although they are not necessarily part of the assembly.

Figure 10 - Optical fiber transition

---

## ANNEX A (NORMATIVE) OPTICAL FIBER CONNECTOR PERFORMANCE SPECIFICATIONS

---

This annex is normative and is considered part of this Standard.

### A.1 Introduction

This annex contains the minimum performance requirements (optical, mechanical and environmental) for optical fiber connectors, adapters and cable assemblies recognized in premises cabling standards.

### A.2 Intermateability requirements

All connectors, adapters and cable assemblies shall comply with the dimensional requirements of the corresponding Fiber Optic Connector Intermateability Standard (FOCIS).

### A.3 Test samples

#### A.3.1 Connector samples

A sample under test shall be a pigtail (one-ended) assembly that consists of two plugs mated in an adapter. The other ends of the pigtails may be unterminated or terminated to interface with the test equipment. Each pigtail shall be a minimum of 3 m (9.8 ft) in length.

##### A.3.1.1 Array connector samples

The outside fibers and one center fiber per row of an array connector shall be monitored (e.g. channels 1, 6 and 12 for a 12-fiber connector).

##### A.3.1.2 Mechanical loading samples

Zipcord cable test samples are considered to be a single mated pair for mechanical loading purposes.

Fiber ribbon test samples are considered to be a single mated pair for mechanical loading purposes if the individual fibers are not separated.

##### A.3.1.3 Test samples with furcation points

If a sample contains a furcation point, the furcation point shall be included as part of the specimen and shall be subjected to environmental exposures (clauses A.4.4, A.4.5 and A.4.6).

### A.4 Performance requirements

All multimode connectors, adapters and cable assemblies shall meet the requirements of this clause at both 850 nm and 1300 nm  $\pm$  30 nm wavelengths. All single-mode connectors, adapters and cable assemblies shall meet the requirements of this clause at both 1310 nm and 1550 nm  $\pm$  30 nm wavelengths. Qualification testing shall be conducted in accordance with the specified TIA Fiber Optic Test Procedure (FOTP) and in accordance with the details specified within this clause. Performance testing does not require any particular test sequence or that the same samples must be used in any series of tests.

#### A.4.1 Visual and mechanical inspections

Test procedure: FOTP-13

Sample size: 24 devices (i.e., pairs of mated connectors)

Details:

- Size measurement methods: per applicable FOCIS
- Deviations: none

## ANSI/TIA-568-C.3

### A.4.2 Attenuation

Test procedure: FOTP-171 Methods A1 or D1, or FOTP-34 Method A2 for multimode  
FOTP-171 Methods A3 or D3, or FOTP-34 Method B for single-mode

Sample size: 24 devices (i.e., pairs of mated connectors)

Details:

- Deviations: For FOTP 171 Methods D1 and D3, a reference quality launch is not used. The launch loss is included with the pair under test.
- Requirement: maximum insertion loss of 0.75 dB.

### A.4.3 Return loss

Test procedure: FOTP-107 or FOTP-8

Sample size: 24 devices (i.e., pairs of mated connectors)

Details:

- Deviations: none
- Requirement: 20 dB minimum for multimode fiber, 26 dB minimum for single-mode fiber, 55 dB minimum for single-mode broadband analog video (CATV) applications.
- For all annex A requirements, the minimum single-mode return loss for broadband analog video (CATV) applications is 55 dB.

### A.4.4 Low temperature

Test procedure: FOTP-188

Sample size: 8 mated connector pairs.

Details:

- Specimen mated
- Temperature: -10 °C (14 °F), preconditioned at ambient conditions 24 hours.
- Duration: 4 days
- Deviations: none
- Initial measurements and performance requirements:
  - maximum insertion loss of 0.75 dB.
- Measurements and performance requirements during test:
  - maximum attenuation increase of 0.3 dB.
- Final measurements and performance requirements:
  - maximum insertion loss of 0.75 dB
  - minimum return loss of 20 dB for multimode, and 26 dB for single-mode

### A.4.5 Temperature life

Test procedure: FOTP-4

Sample size: 8 mated connector pairs.

Details:

- Specimen mated
- Test condition: 60 °C (140 °F)
- Duration: 4 days
- Deviations: none
- Initial measurements and performance requirements:
  - maximum insertion loss of 0.75 dB.
- Measurements and performance requirements during test:
  - none.
- Final measurements and performance requirements:
  - maximum insertion loss of 0.75 dB
  - minimum return loss of 20 dB for multimode, and 26 dB for single-mode

**A.4.6 Humidity**

Test procedure: FOTP-5

Sample size: 8 mated connector pairs.

Details:

- Specimen mated
- Test Method A: steady state
- Preconditioning per FOTP-5 may be performed
- Test Condition A: 96 hours (4 days) of 90 - 95% at  $40 \pm 2$  °C ( $104 \pm 3.6$  °F)
- Deviations: none
- Initial measurements and performance requirements:
  - maximum insertion loss of 0.75 dB.
- Measurements and performance requirements during test:
  - maximum attenuation increase of 0.4 dB.
- Final measurements and performance requirements:
  - maximum insertion loss of 0.75 dB
  - minimum return loss of 20 dB for multimode, and 26 dB for single-mode

**A.4.7 Impact**

Test procedure: FOTP-2

Sample size: 8 mated connector pairs

Details:

- Method B
- Deviations:
  - 1.5 m (4.9 ft) drop height
  - number of drops = 5
  - drop surface is a steel plate with minimum thickness of 12.5 mm (0.5 in)
- Initial measurements and performance requirements:
  - maximum insertion loss of 0.75 dB.
- Measurements and performance requirements during test:
  - none.
- Final measurements and performance requirements:
  - maximum insertion loss of 0.75 dB
  - minimum return loss of 20 dB for multimode, and 26 dB for single-mode

**A.4.8 Strength of coupling mechanism**

Test procedure: FOTP-185

Sample size: 8 mated connector pairs

Details:

- Specimen mated
- Tensile force: 40 N (9.0 lbf) at 0 degree pull angle
- Load application rate: 2 N (0.45 lbf) per second
- Duration: 5 seconds minimum
- Deviations: none
- Initial measurements and performance requirements:
  - maximum insertion loss of 0.75 dB.
- Measurements and performance requirements during test:
  - none.
- Final measurements and performance requirements:
  - maximum insertion loss of 0.75 dB
  - minimum return loss of 20 dB for multimode, and 26 dB for single-mode

## ANSI/TIA-568-C.3

### A.4.9 Durability

Test procedure: FOTP-21

Sample size: 8 mated connector pairs

Details:

- Number of cycles: 500 for simplex, duplex and parallel array applications; 50 for other array applications
- Deviations: none
- Initial measurements and performance requirements:
  - maximum insertion loss of 0.75 dB.
- Measurements and performance requirements during test:
  - none.
- Final measurements and performance requirements:
  - maximum insertion loss of 0.75 dB
  - minimum return loss of 20 dB for multimode, and 26dB for single-mode

### A.4.10 Cable retention

Test procedure: FOTP-6

Test 1: 0 degrees

Sample size: 8 mated connector pairs

Details:

- Specimen mated
- Deviations: none
- Tensile load applied to the cable (for cables with strength members coupled to the connector): 50 N (11.24 lbf) at 0 degree pull angle.
- Tensile load applied to each 250 µm coated fiber or fiber ribbon: 2 N (0.45 lbf).
- Tensile load applied to each buffered fiber: 5 N (1.12 lbf).
- Load application rate of 5 N (1.12 lbf) per second for reinforced cables.
- Load application rate of 0.5 N (0.11 lbf) per second for 250 µm coated fiber and fiber ribbon
- Load application rate of 0.5 N (0.11 lbf) per second for buffered fiber.
- Duration: 5 seconds minimum.
- Initial measurements and performance requirements:
  - maximum insertion loss of 0.75 dB.
- Measurements and performance requirements during test:
  - none.
- Final measurements and performance requirements:
  - maximum attenuation increase 0.5 dB
  - maximum insertions loss of 0.75 dB
  - minimum return loss of 20 dB for multimode, and 26 dB for single-mode

Test 2: 90 degrees

Sample size: 8 mated connector pairs

Details:

- Specimen mated
- Deviations: none
- Tensile load applied to the cable (for cables with strength members terminated to the connector): 19.4 N (4.4 lbf) at 90 degrees pull angle.
- Tensile load applied to each 250 µm coated fiber, buffered fiber or fiber ribbon: 2 N (0.45 lbf) at 90 degrees pull angle.
- Load application rate of 5 N (1.12 lbf) per second for reinforced cables.
- Load application rate of 0.5 N (0.11 lbf) per second for 250 µm coated fiber, buffered fiber and fiber ribbon.



- Duration: 5 seconds minimum
- Initial measurements and performance requirements:
  - maximum insertion loss of 0.75 dB.
- Measurements and performance requirements during test:
  - none.
- Final measurements and performance requirements:
  - maximum attenuation increase 0.5 dB
  - maximum insertion loss of 0.75 dB
  - minimum return loss of 20 dB for multimode, and 26 dB for single-mode

#### **A.4.11 Flex**

Test procedure: FOTP-1

Sample size: 8 mated connector pairs

Details:

- Load applied to the cable (for cables with strength members terminated to the connector): 4.9 N (1.1 lbf).
- Tensile load applied to each 250  $\mu$ m coated fiber, buffered fiber, or fiber ribbon: 2 N (0.45 lbf).
- Test fixture: motor-driven flex fixture.
- Test fixture rotation cycle: 0 degrees, +90 degrees, 0 degrees, -90 degrees, 0 degrees for 100 cycles.
- Deviations: none
- Initial measurements and performance requirements:
  - maximum insertion loss of 0.75 dB.
- Measurements and performance requirements during test:
  - none.
- Final measurements and performance requirements:
  - maximum insertion loss of 0.75 dB
  - minimum return loss of 20 dB for multimode, and 26 dB for single-mode

#### **A.4.12 Twist**

Test procedure: FOTP-36

Sample size: 8 mated connector pairs

Details:

- Specimen mated
- Tensile load:
  - load applied to the cable (for cables with strength members terminated to the connector): 15 N (3.4 lbf).
  - load applied to each 250  $\mu$ m coated fiber, buffered fiber, or fiber ribbon: 2 N (0.45 lbf).
  - load applied at a point 220 - 280 mm (8.6 – 11 in) from connector under test.
  - Rotate through the following cycle 10 times:
    - 2.5 revolutions in one direction, reverse for 5 revolutions, and reverse for 2.5 revolutions to initial position.
- Deviations: none
- Initial measurements and performance requirements:
  - maximum insertion loss of 0.75dB.
- Measurements and performance requirements during test:
  - none.
- Final measurements and performance requirements:
  - maximum insertion loss of 0.75 dB
  - minimum return loss of 20 dB for multimode, and 26 dB for single-mode

---

## ANNEX B (INFORMATIVE) BIBLIOGRAPHY AND REFERENCES

---

This annex is informative only and is not part of this Standard.

The following is a list of some generally applicable basic standards and guides that are relevant to the requirements of this Standard. Other American National Standards also may be relevant.

- ANSI/TIA/EIA-604 series, *FOCIS Fiber Optic Connector Intermateability Standard Types*
- ISO/IEC 11801, *Information Technology – Generic Cabling for Customer Premises*
- ISO/IEC 24702, *Information Technology – Generic Cabling – Industrial Premises*

The organizations listed below can be contacted to obtain reference information.

ANSI (Operations)  
American National Standards Institute (ANSI)  
25 West 43<sup>rd</sup> Street, 4<sup>th</sup> floor  
New York, NY 10036  
USA  
(212) 642-4900  
[www.ansi.org](http://www.ansi.org)

BICSI  
8610 Hidden River Parkway  
Tampa, FL 33637-1000  
USA  
(800) 242-7405  
[www.bicsi.org](http://www.bicsi.org)

ICEA  
Insulated Cable Engineers Association, Inc. (ICEA)  
PO Box 1568  
Carrollton, GA 30112  
USA  
[www.icea.net](http://www.icea.net)

IEC  
International Electrotechnical Commission (IEC)  
Sales Department  
PO Box 131  
3 rue de Varembe  
CH-1211 Geneva 20  
Switzerland  
+41 22 919 02 11  
[www.iec.ch](http://www.iec.ch)

ISO

International Organization for Standardization (ISO)  
1, Rue de Varembe  
Case Postale 56  
CH-1211 Geneva 20  
Switzerland  
+41 22 749 01 11  
[www.iso.ch](http://www.iso.ch)

NFPA

National Fire Protection Association  
1 Batterymarch Park  
Quincy, MA 02169-7471  
USA  
(617) 770-3000  
[www.nfpa.org](http://www.nfpa.org)

TIA

Telecommunications Industry Association (TIA)  
2500 Wilson Blvd., Suite 300  
Arlington, VA 22201-3836  
USA  
(703) 907-7700  
[www.tiaonline.org](http://www.tiaonline.org)





